

---

---

**Resilient and laminate floor coverings —  
Determination of indentation and residual  
indentation —**

**Part 3:  
Indentation of resilient semi-flexible/vinyl  
composition tiles**

*Revêtements de sol résilients et stratifiés — Détermination du  
poinçonnement et du poinçonnement rémanent —*

*Partie 3: Poinçonnement de carreaux semi-flexibles/carreaux de  
composition vinylique résilients*



Reference number  
ISO 24343-3:2011(E)

© ISO 2011



## Foreword

ISO (the International Organization for Standardization) is a worldwide federation of national standards bodies (ISO member bodies). The work of preparing International Standards is normally carried out through ISO technical committees. Each member body interested in a subject for which a technical committee has been established has the right to be represented on that committee. International organizations, governmental and non-governmental, in liaison with ISO, also take part in the work. ISO collaborates closely with the International Electrotechnical Commission (IEC) on all matters of electrotechnical standardization.

International Standards are drafted in accordance with the rules given in the ISO/IEC Directives, Part 2.

The main task of technical committees is to prepare International Standards. Draft International Standards adopted by the technical committees are circulated to the member bodies for voting. Publication as an International Standard requires approval by at least 75 % of the member bodies casting a vote.

Attention is drawn to the possibility that some of the elements of this document may be the subject of patent rights. ISO shall not be held responsible for identifying any or all such patent rights.

ISO 24343-3 was prepared by Technical Committee ISO/TC 219, *Floor coverings*.

ISO 24343 consists of the following parts, under the general title *Resilient and laminate floor coverings — Determination of indentation and residual indentation*:

- *Part 1: Residual indentation*
- *Part 2: Short-term residual indentation of resilient floor covering*
- *Part 3: Indentation of resilient semi-flexible/vinyl composition tiles*



# Resilient and laminate floor coverings — Determination of indentation and residual indentation —

## Part 3: Indentation of resilient semi-flexible/vinyl composition tiles

### 1 Scope

This part of ISO 24343 describes a method for determining the short-term indentation resistance of resilient semi-flexible/vinyl composition tile (VCT) floor covering after the application of constant load.

### 2 Terms and definitions

For the purposes of this document, the following terms and definitions apply.

#### 2.1

##### **indentation**

difference between the initial thickness and the thickness measured after removal of the load

#### 2.2

##### **thickness**

distance between two parallel plates where the floor covering is inserted under a specific load

### 3 Principle

Tests pieces are subjected to static loading at room temperature, the thickness being measured before and during loading at specified dwell periods.

### 4 Apparatus

**4.1 Water bath**, capable of maintaining a temperature of  $(23 \pm 2,0)$  °C.

NOTE This is optional.

**4.2 Indenter**, a straight, steel cylinder of diameter as specified below with a hemispherical tip.

Diameter of the indenter:  $(6,35 \pm 0,01)$  mm; weight of the indenter:  $(0,90 \pm 0,05)$  kg.

**4.3 Rigid, horizontal platform**, of minimum diameter 35 mm.

**4.5 Device**, by means of which a force of  $(13,60 \pm 0,12)$  kg can be smoothly applied. The frame shall not deform by more than 0,05 mm measured in the direction of the axis under the maximum force.

**4.5 Comparator**, for measuring the depth of indentation to  $\pm 0,01$  mm.

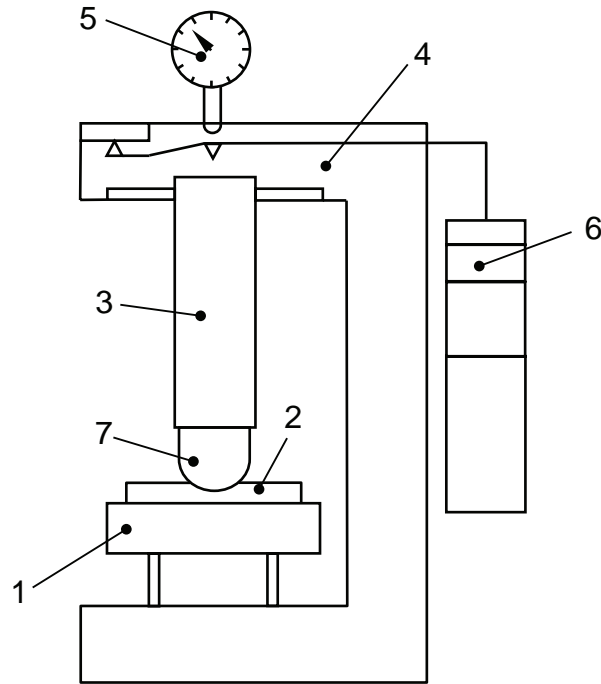

**Key**

- 1 horizontal platform
- 2 test piece
- 3 annular weight
- 4 lever arm
- 5 comparator
- 6 dead weight
- 7 indenter

**Figure 1 — Example of a device to apply force on an indenter**

**4.6 Apparatus**, for measuring the thickness of the test piece to 0,01 mm.

Diameter of the foot:  $(3,50 \pm 0,02)$  mm; mass applied  $(0,085 \pm 0,003)$  kg.

**4.7 Stopwatch**, or other timing device.

**5 Atmosphere for conditioning and testing**

Unless stated otherwise in the product specification, condition the test pieces at a temperature of  $(23 \pm 2,0)$  °C and a relative humidity of  $(50 \pm 5)$  % for a minimum of 1 h. Maintain these conditions when carrying out the test. Test pieces may also be conditioned by means of a water bath as described in 4.1 for a minimum of 1 h.

**6 Sampling and selection of specimens**

Take a representative sample from the available material. Take three test pieces with dimensions at least 50 mm by 50 mm cut from different tiles or planks.

**7 Test procedure**

**7.1** Condition the test piece as specified in Clause 5.

**7.2** Mark the place of measurement and measure the initial thickness of the test piece,  $t_0$ , at its centre to 0,01 mm, using the appropriate mass specified in 4.5.

**7.3** Place the test piece on the platform and centre the marked place of measurement directly under the indenting tip.

**7.4** Place the indenter on the marked spot and adjust the comparator to zero. Gently apply the total force specified in 4.3 and start the stopwatch within 2 s.

**7.5** Record the depth of indentation,  $t_1$ , after  $(60 \pm 1)$  s to 0,01 mm while continuing to maintain the force on the test piece.

**7.6** After a further  $(540 \pm 2)$  s, record the depth of indentation,  $t_2$ , of the test piece.

**7.7** Repeat the test on the remaining test pieces. Calculate the mean value from the measurements taken and express the result to 0,01 mm.

## 8 Calculation and expression of results

**8.1** Record the one minute indentation,  $t_1$ , for each test piece.

**8.2** Record the ten minute indentation,  $t_2$ , for each test piece.

**8.3** Calculate the mean value for both the one minute and the ten minute indentations and express the result to the nearest 0,01 mm.

## 9 Precision statement

A round robin test shall be conducted to determine the precision of this test method.

## 10 Test report

The test report shall contain the following information:

- a) a statement that the tests were performed in accordance with this part of ISO 24343, i.e. ISO 24343-3;
- b) complete identification of the product tested, including type, source, colour, and manufacturer's reference numbers;
- c) history of the sample;
- d) the individual and mean values for the one minute indentation to the nearest 0,01 mm;
- e) the individual and mean values for the ten minute indentation to the nearest 0,01 mm;
- f) any deviation from this part of ISO 24343 which could have affected the results.

## Bibliography

- [1] ASTM F 1066, Standard Specification for Vinyl Composition Floor Tile
- [2] ASTM F 1914, Standard Test Methods for Short-Term Indentation and Residual Indentation of Resilient Floor Covering
- [3] JIS A 1454, Test methods — Resilient floorcoverings





---

---

**ICS 97.150**

Price based on 4 pages